

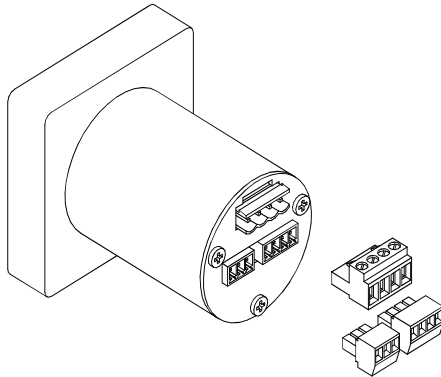

## FS11X - XXX INSTALLATION - SETUP - OPERATION INSTRUCTIONS

### FS11X-XXX DESCRIPTION / SPECIFICATIONS



- DIGITAL DISPLAY - 4 Digit, 0.4" Tall Red LED; -1999 to 9999 display range
- BARGRAPH DISPLAY - 21 Element Red T1 LED's arranged in an arc above the digital display.
- ENCLOSURE - Painted steel, Aluminum and Stainless Steel
- MOUNTING - A separate stainless steel mounting bracket attaches to the rear of the meter and physically clamps the meter to the panel through a 2 1/8" round opening.
- OVERALL ACCURACY - Better than .05% F.S. over operating temperature range. Accuracy at fixed temperature better than .02% F.S.
- OPERATING TEMPERATURE RANGE - -25 Degrees C to +80 Degrees C
- STORAGE TEMPERATURE RANGE - -55 Degrees C to +80 Degrees C
- A/D CONVERTER RESOLUTION - 16 Bits ( 65536 counts )
- A/D CONVERSION RATE - 4000 Conversions / second
- DISPLAY UPDATE RATE - From 16 to 1 updates per second user selectable
- RESPONSE TIME - 0.5 seconds for full scale step
- OPTIONAL SETPOINT RELAYS - 2 on-board 1 Amp @ 200V AC/DC isolated MOSFET solid state relays with a 4 position socketed terminal block for connection are available. The trip point for each relay is programmable via the front panel menu switches. Each relay is independently programmable as NO (form A) or NC (form B).
- OVER / UNDER RANGE INDICATION - Meter displays '-or-' or '-ur-' when input exceeds min/max displayable range or min/max input range
- BAR DISPLAY MODES - Moving dot and fill modes, menu selectable
- CALIBRATION / DISPLAY SCALING - Two menu steps allow entry of any 2 known display points; a known input is necessary for scaling
- DECIMAL POINT - Selectable for 0, 0.0, 0.00, 0.000, display precision
- OPTIONAL ISOLATED EXCITATION - An internal isolated 24 VDC @ 30 mA or 10 VDC @ 50 mA unregulated power supply is available for powering loop powered sensors or transducers.

Model	Signal Input	Model	Signal Input	Model	Signal Input
FS11X-100	Process, 4 to 20mA	FS11X-540	Thermometer, Type T T/C	FS11X-810	AC voltmeter, 200mVAC
FS11X-110	Process, 1 to 5VDC	FS11X-610	DC voltmeter, 200mVDC	FS11X-820	AC voltmeter, 2VAC
FS11X-120	Process, 0 to 10VDC	FS11X-620	DC voltmeter, 2VDC	FS11X-830	AC voltmeter, 20VAC
FS11X-200	Thermometer, 100 ohm RTD	FS11X-630	DC voltmeter, 20DC	FS11X-840	AC voltmeter, 200VAC
FS11X-300	Resistance, 20 Ohm	FS11X-640	DC voltmeter, 200C	FS11X-850	AC voltmeter, 600VAC
FS11X-310	Resistance, 200 Ohm	FS11X-650	DC voltmeter, 600VDC	FS11X-910	AC ammeter, 200mAAC
FS11X-320	Resistance, 2K Ohm	FS11X-700	DC Ammeter ±50uADC, internal shunt	FS11X-920	AC ammeter, 2AAC
FS11X-340	Resistance, 20K Ohm	FS11X-710	DC Ammeter ±200mADC, internal shunt	FS11X-930	AC ammeter, 20AAC
FS11X-400	Straingauge, 30mV w/10VDC excitation	FS11X-720	DC Ammeter ±2ADC, external shunt	FS11X-940	AC ammeter, 200AAC
FS11X-500	Thermometer, Type J T/C	FS11X-730	DC Ammeter ±20ADC, external shunt		
FS11X-510	Thermometer, Type K T/C	FS11X-740	DC Ammeter ±200ADC, external shunt		

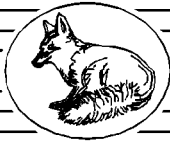

## FS11X-XXX SERIES MOUNTING

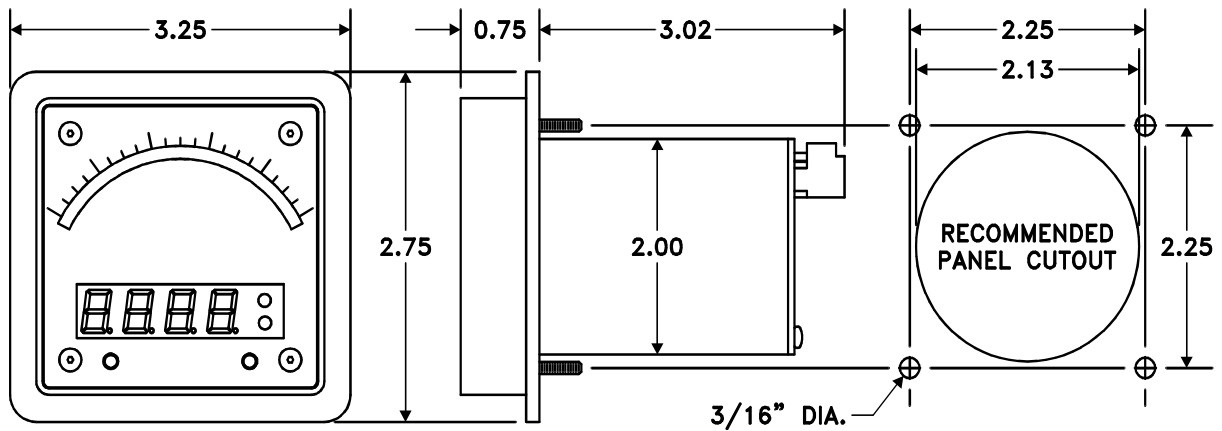

## FS11X-XXX SERIES POWER SUPPLY SPECIFICATIONS

### FS111 - XXX 120 VAC UNITS

- INPUT VOLTAGE RANGE - 85 to 140 VAC
- INPUT FREQUENCY RANGE - 47 to 63 Hz
- POWER DISSIPATION - Less than 3 VA typical

#### P2 WIRING

- P2 - 1 : Neutral Line
- P2 - 2 : 120 VAC Hot Line
- P2 - 3 : Chassis ground

### FS113 - XXX 240 VAC UNITS

- INPUT VOLTAGE RANGE - 190 to 260 VAC
- INPUT FREQUENCY RANGE - 47 to 63 Hz
- POWER DISSIPATION - Less than 3 VA typical

#### P2 WIRING

- P2 - 1 : 240 VAC Hot Line
- P2 - 2 : 240 VAC Hot Line
- P2 - 3 : Chassis ground

### FS115 - XXX 5 TO 12 VDC UNITS

- INPUT VOLTAGE RANGE - 5 TO 12 VDC
- PERMISSABLE RIPPLE - 200 mV Max
- INPUT CURRENT - Less than 200 mA typical

#### P2 WIRING

- P2 - 1 : +DC
- P2 - 2 : Power supply ground
- P2 - 3 : Chassis ground

### FS116 - XXX 5 TO 12 VDC ISOLATED UNITS

- INPUT VOLTAGE RANGE - 5 TO 12 VDC
- PERMISSABLE RIPPLE - 200 mV Max
- INPUT CURRENT - Less than 200 mA typical
- POWER SUPPLY ISOLATION - 750 Volts isolation between power supply and signal input

#### P2 WIRING

- P2 - 1 : +DC
- P2 - 2 : Power supply ground
- P2 - 3 : Chassis ground

### FS117 - XXX 10 TO 30 VDC UNITS

- INPUT VOLTAGE RANGE - 10 TO 30 VDC
- PERMISSABLE RIPPLE - 500 mV Max
- INPUT CURRENT - Less than 150 mA typical

#### P2 WIRING

- P2 - 1 : +DC
- P2 - 2 : Power supply ground
- P2 - 3 : Chassis ground

### FS118 - XXX 10 TO 30 VDC ISOLATED UNITS

- INPUT VOLTAGE RANGE - 10 TO 30 VDC
- PERMISSABLE RIPPLE - 500 mV Max
- INPUT CURRENT - Less than 150 mA typical
- POWER SUPPLY ISOLATION - 750 Volts isolation between power supply and signal input

#### P2 WIRING

- P2 - 1 : +DC
- P2 - 2 : Power supply ground
- P2 - 3 : Chassis ground



## FS11X - XXX SERIES WIRING GUIDE

### P1 - SIGNAL INPUT

- P1 - 1: - SIGNAL INPUT\*\*\*
- P1 - 2: + SIGNAL INPUT
- P1 - 3: - EXCITATION OUTPUT\*
- P1 - 4: + EXCITATION OUTPUT\*

\* EXCITATION IS ONLY PRESENT IF THE METER IS ORDERED WITH THE EXCITATION OPTION.

### P2 - POWER INPUT

SEE POWER SUPPLY SPECIFICATIONS (PAGE 2) FOR CONNECTION INFORMATION.

\*\*\* THE - SIGNAL INPUT IS COMMON TO THE POWER SUPPLY GROUND ON FS11X SERIES METERS. WHEN USING DC POWERED FS11X SERIES METERS, CARE SHOULD BE TAKEN TO NOT CREATE GROUND LOOPS WITH SIGNAL WIRING. IF GROUND LOOPS ARE A CONSIDERATION, USE AC POWER OR ISOLATED DC POWERED UNITS.

### P3 - SETPOINT OUTPUTS

- P3-1 & P3-2 = SETPOINT 1
- P3-3 & P3-4 = SETPOINT 2

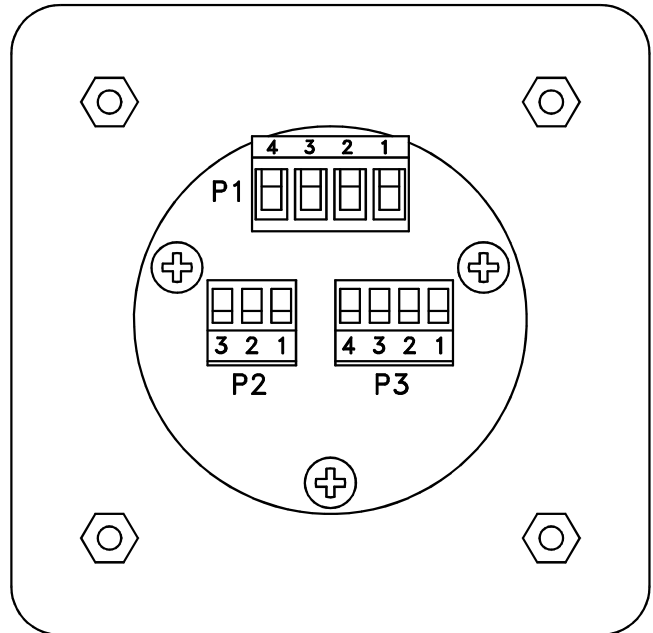

REAR VIEW OF FS11X-XXX SERIES UNITS

## FS11X - XXX SERIES FRONT PANEL CONTROLS



### STEP

- PRESS TO ENTER THE SETUP MENU
- WHILE IN THE MENU MODE, PRESS THIS BUTTON TO ADVANCE TO THE NEXT PARAMETER OR TO THE NEXT DIGIT

### SET

- WHILE IN THE MENU MODE, THIS BUTTON CHANGES THE SETTING FOR A PARAMETER OR INCREMENTS THE FLASHING DIGIT



## FS11X - XXX SERIES SET-UP MENU

PARAMETER	SETTING	DESCRIPTION
DECIMAL POINT	D 0	NO DECIMAL PLACES
	D 0.0	ONE DECIMAL PLACES
	D 0.00	TWO DECIMAL PLACES
	D.000	THREE DECIMAL PLACES
AVERAGING: NUMBER OF SETS OF 256 CONVERSIONS AVERAGED TOGETHER FOR DISPLAY UPDATE	Av.16	4096 CONVERSIONS AVERAGED; 1 UPDATE / SECOND
	Av. 8	2048 CONVERSIONS AVERAGED; 2 UPDATES / SECOND
	Av. 4	1024 CONVERSIONS AVERAGED; 4 UPDATES / SECOND
	Av. 2	512 CONVERSIONS AVERAGED; 8 UPDATES / SECOND
	Av. 1	256 CONVERSIONS AVERAGED; 16 UPDATES / SECOND
BAR MODE	FILL	BAR DISPLAY FILLS FROM LEFT
	dot	MOVING DOT BAR DISPLAY
BAR STARTING POINT	[1][2][3][4]	ENTER DISPLAY VALUE AT LEFT END OF BAR
BAR ENDING POINT	[1][2][3][4]	ENTER DISPLAY VALUE AT RIGHT END OF BAR
SETPOINT 1 LEVEL	S1.no	SETPOINT 1 OPEN WHEN DISPLAY IS BELOW SP1 VALUE
	S1.nc	SETPOINT 1 CLOSED WHEN DISPLAY IS BELOW SP1 VALUE
SETPOINT 1 VALUE	[1][2][3][4]	ENTER SETPOINT 1 DISPLAY VALUE
SETPOINT 2 LEVEL	S2.no	SETPOINT 2 OPEN WHEN DISPLAY IS BELOW SP2 VALUE
	S2.nc	SETPOINT 2 CLOSED WHEN DISPLAY IS BELOW SP2 VALUE
SETPOINT 2 VALUE	[1][2][3][4]	ENTER SETPOINT 2 DISPLAY VALUE
CAL POINT 1	CAL1	ANNOUNCES CAL 1 STEP *
	[1][2][3][4]	ADJUST DISPLAY TO DESIRED mV VALUE FOR CAL 1 INPUT *
CAL POINT 2	CAL2	ANNOUNCES CAL 2 STEP *
	[1][2][3][4]	ADJUST DISPLAY TO DESIRED mV VALUE FOR CAL 2 INPUT *

### TO SET A CALIBRATION / SCALING VALUE:

- PRESS AND RELEASE THE 'SET' BUTTON UNTIL THE FLASHING DIGIT REACHES THE DESIRED VALUE
- PRESS THE 'STEP' BUTTON TO ADVANCE TO THE NEXT DIGIT
- REPEAT UNTIL ALL DIGITS ARE SET
- NOTE: LEADING ZERO SUPPRESSION IS DISABLED DURING SETUP MENU OPERATION, ALL FOUR DIGITS MUST DISPLAY A NUMBER

### \* CALIBRATION / SCALING INSTRUCTIONS:

- THE FS12X - XXX SERIES REQUIRES 2 KNOWN INPUTS FOR CALIBRATION / SCALING. THESE INPUTS CAN BE OF ANY POLARITY WITH RESPECT TO EACH OTHER AND SHOULD BE AS FAR APART AS POSSIBLE IN MAGNITUDE.
- APPLY THE FIRST KNOWN INPUT SIGNAL TO THE METER INPUT.
- USING THE 'STEP' BUTTON, SCROLL THROUGH THE SETUP MENU UNTIL THE BAR SENSITIVITY STEP APPEARS. PRESS AND HOLD THE 'STEP' BUTTON ONCE MORE UNTIL THE CAL1 MESSAGE IS REPLACED BY A NUMBER WITH THE MSD (LEFT) DIGIT FLASHING.
- ADJUST THE VALUE ON THE DISPLAY UNTIL IT IS AT THE DESIRED VALUE FOR THE KNOWN INPUT - SEE ABOVE INSTRUCTIONS TO SET A CALIBRATION / SCALING VALUE
- SIMULTANEOUSLY PRESS BOTH THE 'SETPT / RESET' AND 'TARE' BUTTONS TO ENTER THE CAL POINT
- PRESS THE 'STEP' BUTTON, THE 'ENT 1' MESSAGE WILL APPEAR MOMENTARILY AND THEN BE REPLACED WITH THE CAL2 MESSAGE- PRESS 'STEP' ONCE MORE- A NUMBER WILL APPEAR WITH THE MSD (LEFT) DIGIT FLASHING.
- APPLY THE SECOND KNOWN INPUT SIGNAL TO THE METER INPUT
- ADJUST THE VALUE ON THE DISPLAY UNTIL IT IS AT THE DESIRED VALUE FOR THE KNOWN INPUT - SEE ABOVE INSTRUCTIONS TO SET A CALIBRATION / SCALING VALUE
- PRESS 'STEP' BUTTON TO ENTER THE CAL POINT, CALIBRATION / SCALING IS COMPLETE - THE METER WILL RETURN TO NORMAL OPERATION



# FOX

## WARRANTY

- FOX METER INC., warrants its products to be free from defective material or workmanship for a period of two years from date of purchase.
- FOX METER INC., under this warranty is limited to repairing the defective device when returned to the factory, shipping charges prepaid, within two full years from date of purchase.
- This warranty is transferrable to second and third parties and will remain in force for the two year term from date of original purchase from FOX METER INC.
- Units returned to FOX METER INC., that have been subject to abuse, misuse, damage or accident, or have been connected, installed or adjusted contrary to the instructions furnished by FOX METER INC., or that have been repaired by unauthorized persons will not be covered by this warranty.
- The purchaser agrees to assume all liabilities for any damages and/or bodily injury which may result from the use or misuse of the device by the purchaser, his employees, or agents.
- This warranty is in lieu of all other representations or warranties, expressed or implied and no agent or representative of FOX METER INC., is authorized to assume any other obligation in connection with the sale and purchase of FOX METER INC., products.
- The terms of this warranty will only be honored if the products or equipment for which warranty service has been requested have been paid for in full by the original purchaser within the agreed upon terms and conditions of sale.

### \* NOTE \*

- While FOX METER INC., provides application assistance on its products, personally and through our literature, it is the responsibility of the customer to determine the compatibility of the product in the application.

## FACTORY SERVICE AND REPAIR

- FOX METER INC., will service and repair this instrument free of charge for the period of two years, subject to the warranty conditions above.
- When returning any defective product to FOX METER INC., please include any information that may pertain to the problem and please include the name of the individual for us to contact, along with your company name, address and phone number.

## RETURN REPAIRS TO

**FOX METER INC.  
302 W. Lincoln Hwy. Suite 2  
Cortland, IL 60112  
ATTN: Service Department**